

Mid Rise Scissor Lift
Lifting Capacity: 3000KG

SCT-7530

MANUAL OPERATION

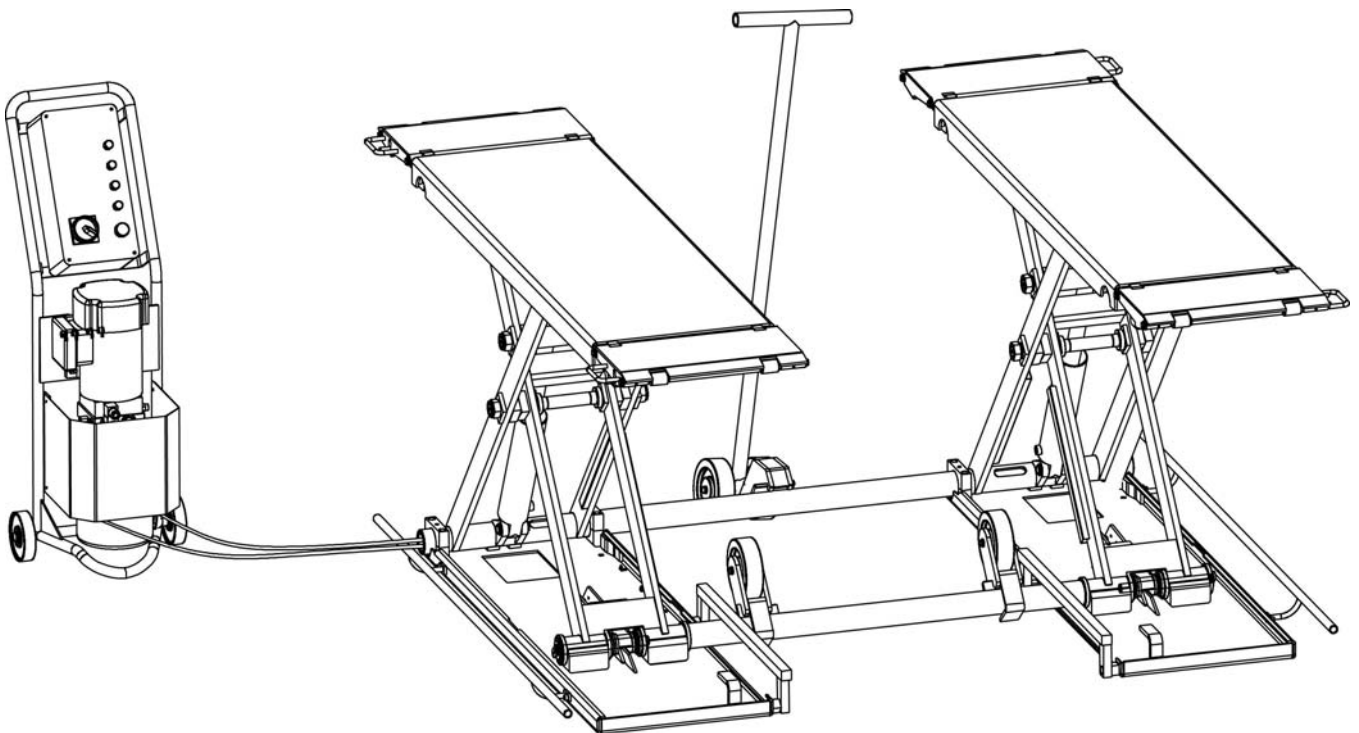

Read this entire manual carefully and completely before installation and operation of the lift.

INDEX

1. Important safety instructions.....3

- 1.1 Important notices
- 1.2 Qualified personnel
- 1.3 Danger notices
- 1.4 Warning signs
- 1.5 Sound level
- 1.6 Training

2. Overview of the lift.....	4
2.1 General descriptions	
2.2 Technical data	
2.3 Construction of the lift	
3. Installation instructions.....	5
3.1 Preparations before installation	
3.1.1 Tools and equipments needed	
3.1.2 A list for parts checking	
3.1.3 Ground conditions	
3.2 Precautions for installation	
3.3 Installation	
3.4 Items to be checked after installation	
4. Operation instructions.....	7
4.1 Precautions	
4.2 Descriptions of control box	
4.3 Flow chart for operation	
4.4 Operating instructions	
4.5 Emergency lowering in case of no power	
5. Trouble shooting.....	10
6. Maintenance.....	12
7. Annex.....	13
Annex1, Packing list of the whole lift	
Annex2, Overall diagram	
Annex3, Hydraulic working system	
Annex4, Diagram for pneumatic system.	
Annex5, Wiring diagram	
Annex6, Separate diagrams for the lift	
Annex7. Spare parts list	
Annex8, Size and weight requirements on vehicles	

1. IMPORTANT SAFETY INSTRUCTIONS

1.1 Important notices

Friend will offer one-year's quality warranty for the whole machine, during which any quality problem will be properly solved to the user's satisfaction. However, we will not take any responsibility for whatever bad consequence resulted from improper installation and operation, overload running or unqualified ground condition.

This middle rise scissor lift is especially fit for tire service or other quick service around vehicles. Users must always bear in mind that this SCT-7530 is specially designed for lifting cars or other vehicles, so never use it for any other purposes. Otherwise, we, as well as our sales agency, will not bear any responsibility for accidents or damages of the lift.

Make sure to pay careful attention to the label of the lifting capacity attached on the lift and never try to lift cars with its weight beyond.

Read this manual carefully before operating the machine so as to avoid economic loss or personnel casualty incurred by wrong operation.

Without our professional advice, users are not permitted to make any modification to the control unit or whatever mechanical unit.

1.2 Qualified personnel

1.2.1 Only these qualified staff, who have been properly trained, can operate the lift.

1.2.2 Electrical connection must be done by a competent electrician.

1.2.3 People who are not concerned are not allowed in the lifting area.

1.3 Danger notices

1.3.1 Do not install the lift on any asphalt surface.

1.3.2 Read and understand all safety warnings before operating the lift.

1.3.3 Do not leave the controls while the lift is still in motion.

1.3.4 Keep hands and feet away from any moving parts. Keep feet clear of the lift when lowering.

1.3.5 Only these properly trained personnel can operate the lift.

1.3.6 Do not wear unfit clothes such as large clothes with flounces, tires, etc, which could be caught by moving parts of the lift.

1.3.7 To prevent evitable incidents, surrounding areas of the lift must be tidy and with nothing unconcerned.

1.3.8 The lift is simply designed to lift the entire body of vehicles, with its maximum weight within the lifting capacity.

1.3.9 Always insure the safety locks are engaged before any attempt to work near or under the vehicle. Never remove safety related components from the lift. Do not use if safety related components are damaged or missing.

1.3.10 Do not rock the vehicle while on the lift or remove any heavy component from vehicle that may cause excessive weight shift.

1.3.11 Check at any time the parts of the lift to ensure the agility of moving parts and the performance of synchronization. Ensure regular maintenance and if anything abnormal occurs, stop using the lift immediately and contact our dealers for help.

1.3.12 Lower the lift to its lowest position and do remember to cut off the power source when service finishes.

1.3.13 Do not modify any parts of the lift without manufacturer's advice.

1.3.14 If the lift is going to be left unused for a long time, users are required to:

- a. Disconnect the power source;
- b. Empty the oil tank;
- c. Lubricate the moving parts with hydraulic oil.

Attention: For environment protection, please dispose the disused oil in a proper way.

1.4 Warnings (Read and understand all safety warnings before operation)

All safety warning labels are clearly depicted on the lift to ensure that the operator is aware of and avoids the dangers of using the lift in an incorrect manner. The labels must be kept clean and they have to be replaced if detached or damaged. Please read carefully the meaning of each label and memorize them for future operation.



1.5 Sound Level

The sound emitted from the lift should not exceed 75DB. For the sake of your health, we suggest putting a noise detector in your working area.

1.6 Training

Only properly trained people are allowed to operate the lift. We are quite willing to provide professional training for the users when necessary.

2. Overview of the lift

2.1 General descriptions

The lift is driven by an electro-hydraulic system. The gear pump delivers hydraulic oil to oil cylinders and pushes upwards their pistons to raise the platforms. For this model, we offer two safety solutions: one with anti-surge valve in hydraulic system to prevent sudden drop down of platform in case the oil hose broke, the other with anti-surge valve and an extra pneumatic safety lock.

Pneumatic safety lock.

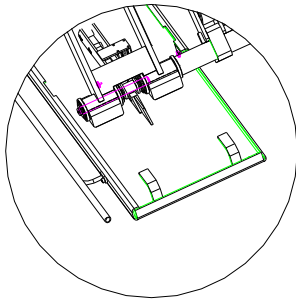

2.2 Technical data

Model	Lifting capacity	Lifting time	Lifting height	Power supply
SCT-7530	3000KG	30S	1000mm	220V/240V,single phase/380V/415Vthree phase

2.3 Construction of the lift

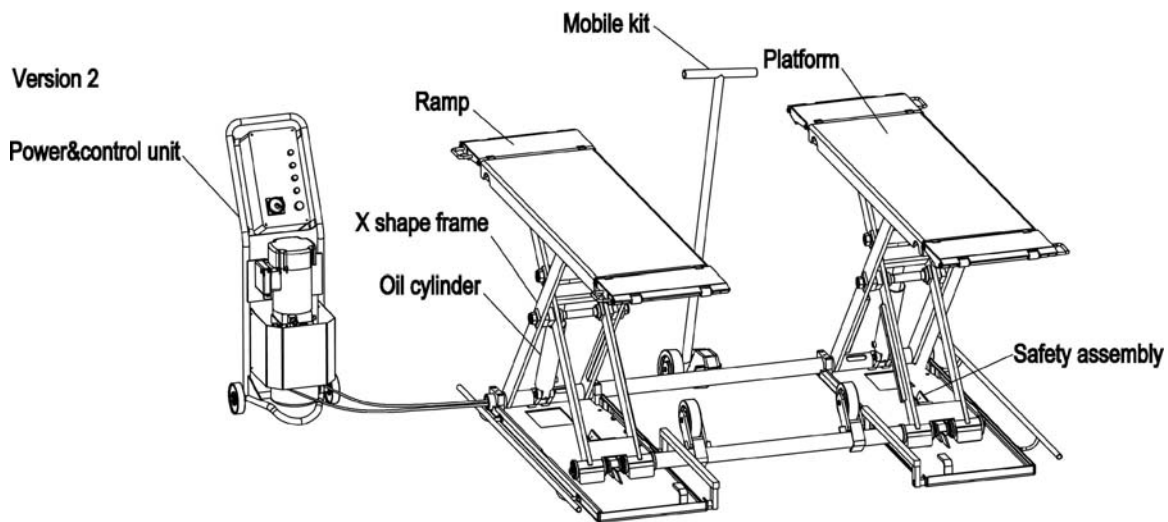

3. Installation instructions

3.1 Preparations before installation

3.1.1 Tools and equipments needed

- √ Electrical drill
- √ Open wrenches
- √ Screw drivers
- √ Adjustable spanners



3.1.2 List for parts checking ---Annex 1 (Packing list)

Unfold the package and check if any parts missed as per Annex 1. Do not hesitate to contact us in case any parts missed, but if you do not contact us and insist installing upon the lack of some parts, Friend as well as our dealers will not bear any

responsibility for this and will charge for any parts subsequently demanded by the buyer.

3.1.3 Ground conditions

The lift should be fixed on a smooth and solid concrete ground with its strength more than 3000psi, tolerance of flatness less than 5mm and minimum thickness of 200mm. In addition, newly built concrete ground must undergo more than 28days' cure and reinforcement.

3.2 Precautions for installation

3.2.2 Joints of oil hose must be firmly connected in order to avoid leakage.

3.2.3 All bolts should be firmly screwed up.

3.2.4 Do not place any vehicle on the lift in the case of trial running.

3.3 Installation

Step 1: Remove the packaging and take the mechanical and hydraulic assembly to the designated installing place. Please do read and understand this manual thoroughly before next step.

Step 2: Connect the oil hose to the pump assembly with a proper wrench. (Make sure the hose end is clean).



Step3: Connect the wires of limit switch to the wiring terminals in the control box. Make sure to connect NO.1 wire with NO.1 terminal, NO.2 wire with NO.2 terminal and so forth.

Step4: Link the air hose to compressed air source. (This step is only for the type with pneumatic safety lock)



Step 5: Fix the base frame. (Optional)

This SCT-7530 is portable. In other words users may use it without having it placed and fixed on the ground. Nevertheless, if you want to have it fixed, do fix it on a smooth and solid concrete surface.

Step 6: Trial testing with load. (Do not use cars for trial testing)

Load applied shall not exceed 2500KG.

This step is of particular importance for it can check if the oil hose and air hose are well connected. Connections are qualified when there is no abnormal sound or leakage after having been tested for 2 or 3 times.

3.4 Items to be checked after installation

S/N	Check items	YES	NO
1	Are two platforms on the same level?		
2	Are oil hoses well connected?		
3	Are electrical connections correct?		
4	Do valves on the pump assembly leak?		

4. Operation instructions

4.1 Precautions

- 4.1.1 Check all the joints of oil hose. Only when there is no leakage, the lift can start work.
- 4.1.2 The lift, if its safety device malfunctions, shall not be used.
- 4.1.3 The machine shall not lift or lower an automobile if its center of gravity is not positioned midway of the rising platforms. Otherwise, the manufacturer as well as our dealers will not bear any responsibility for any consequence resulted thereby.
- 4.1.4 Operators and other personnel concerned should stand in a safety area during lifting and lowering process.
- 4.1.5 When platforms rise to the desired height, switch off the power at once to prevent any wrong operation done by untrained people.
- 4.1.6. Make sure the safety lock of the lift is engaged before start working under the vehicle and no people under the vehicle during lifting and lowering process.

4.2 Descriptions of control box

Control panel for version 1

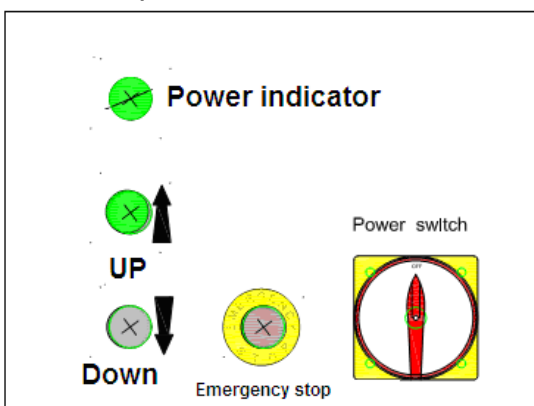

Control panel for version 2

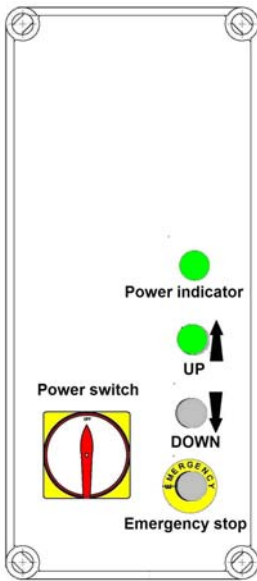

4.3 Flow chart for operation

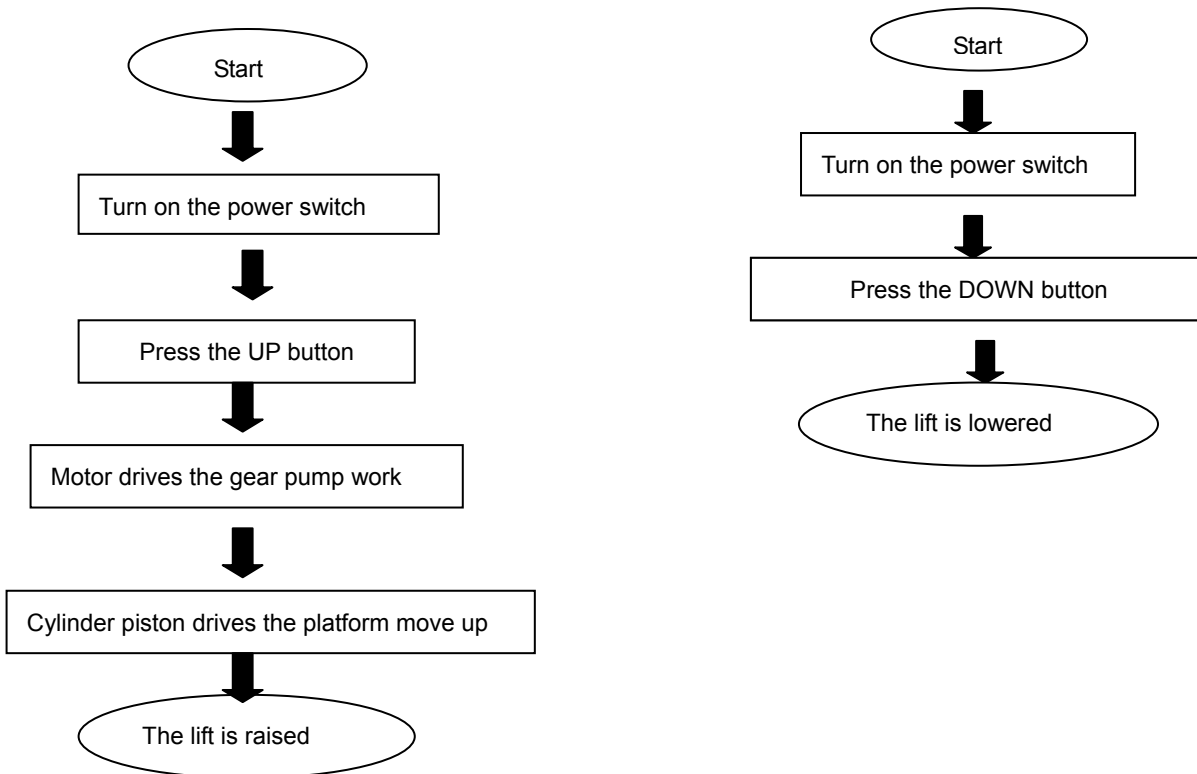

4.4 Operation instructions

Raise the lift

1. Make sure that you have read and understood the operation manual before operation.
2. Drive and park the vehicle midway between two platforms.
3. Place the four rubber pads under the prop-points of the vehicle and ensure car's gravity have fallen on the rubber pads.
4. Press the UP button on the control box until rubber pads have touched the prop-points of vehicle.
5. Keep on pressing the UP button to lift the vehicle a bit higher from the ground and check again if the vehicle is in a safe position.

6. Having raised the vehicle to the required height, press the “Emergency stop” button before performing maintenance or repair work.

Lower the lift

1. Switch on (press the “emergency stop button” until the power indicator is on).
2. Press the DOWN button to lower the lift. (For the model with pneumatic safety lock, firstly platforms of the lift will rise about 5cm which is to release the safety lock; for the model without pneumatic safety lock, platforms will go down directly.)
3. Drive away the vehicle.

4.5 Emergency lowering in case of no power

The safety lock is not engaged :

- a. Tie up the safety teeth on both sides with rope; pull upward the rope making the safety teeth unlocked.

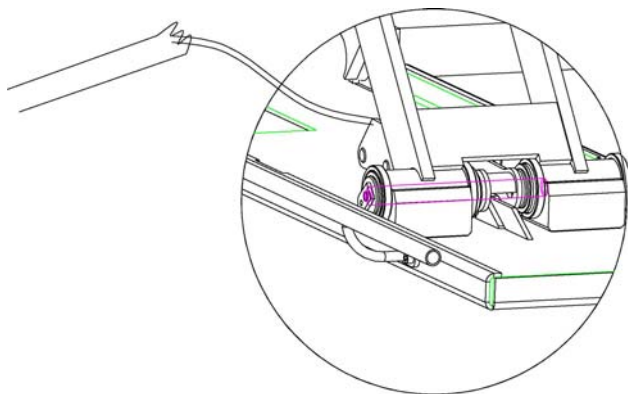

- b. Having the safety teeth unlocked, manually loose the core of electro-magnetic valve on the pump assembly.

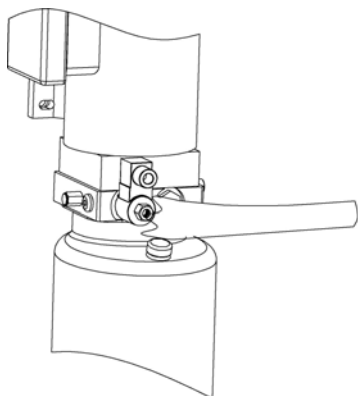

The safety lock is engaged:

- a. Screw off the fitting (opposite to the oil out-let) to connect a hand pump. (Optional)

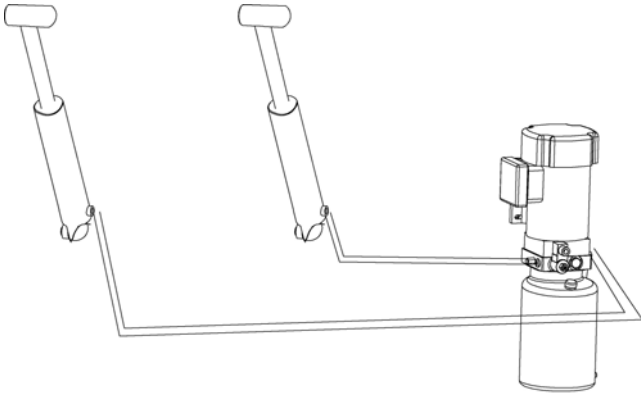

b. Connect the hydraulic assembly with the optional hand pump. Press down the handle of the pump to raise the platforms to have the safety teeth unlocked.

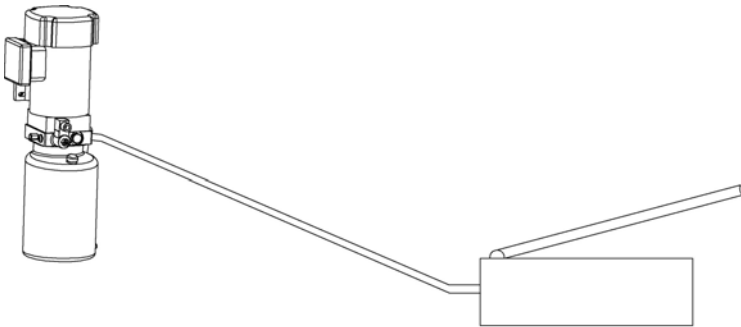

c. Tie up the safety teeth with rope and pull up the safety teeth.

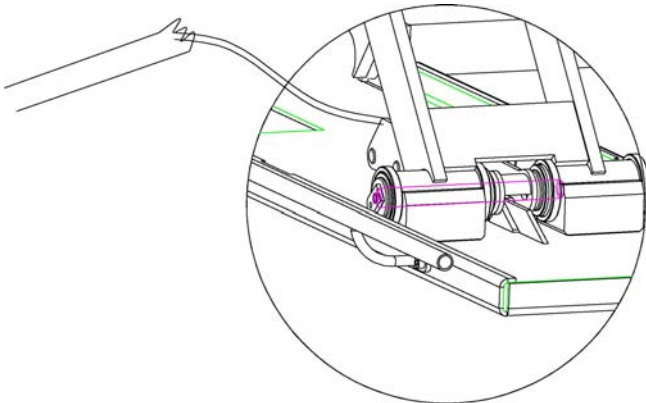

d. Use a wrench to loose the core of the electro-magnetic valve to lower the platforms.

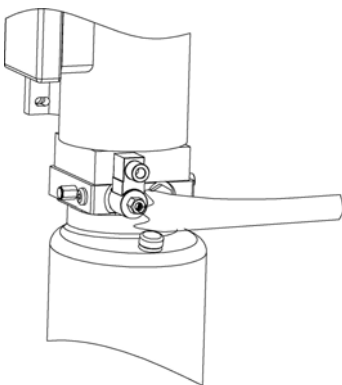

5. Trouble Shooting

ATTENTION: If the trouble could not be fixed by yourself, please do not hesitate to contact us for help .We will offer our service at the earliest time we can. By the way, your troubles will be judged and solved much faster if you could provide us more details or pictures of the trouble.

TROUBLES	CAUSE	SOLUTION
Motor does not run and will not raise	The wire connection is loose.	Check and make a good connection.
	The motor is burnt	Replace it.
	The limit switch is damaged or the wire connection is loose.	Connect it or adjust or replace the limit switch.
Motor runs but will not raise	The motor run reversely.	Check the wire connection.
	Overflow valve is loose or jammed.	Clean or adjust it.
	The gear pump is damaged.	Replace it.
	Oil level is too low.	Add oil.
	The oil hose became loose or dropped off.	Tighten it.
	The cushion valve became loose or jammed.	Clean or adjusts it.
Platforms go down slowly after being raised	The oil hose leaks.	Check or replace it.
	The oil cylinder is not tightened.	Replace the seal.
	The single valve leaks.	Clean or replace it.
	The overflow valve leaks.	Clean or replace it.
	Electrical unloading valve leaks.	Clean or replace it.
Raising too slow	The oil filter is jammed.	Clean or replace it.
	Oil level is too low.	Add oil.
	The overflow valve is not adjusted to the right position.	Adjust it.
	The hydraulic oil is too hot (above 45°).	Change the oil.
	The seal of the cylinder is abraded.	Replace the seal.
Lowering too slow	The throttle valve jammed.	Clean or replace.
	The hydraulic oil is dirty.	Change the oil.
	The anti-surge valve jammed.	Clean it.
	The oil hose jammed.	Replace it.

6. Maintenance

Easy and low cost routine maintenance can ensure the lift work normally and safely. Following are requirements for routine maintenance. You may choose the frequency of routine maintenance by consulting your lift's working conditions and time.

THE FOLLOWING PARTS NEED TO BE LUBRICATED

S/N	Description
1	Small idler wheel
2	Rotor shaft
3	U-shape block
4	Safety shaft
5	Rotor shaft of oil tank
6	Slider

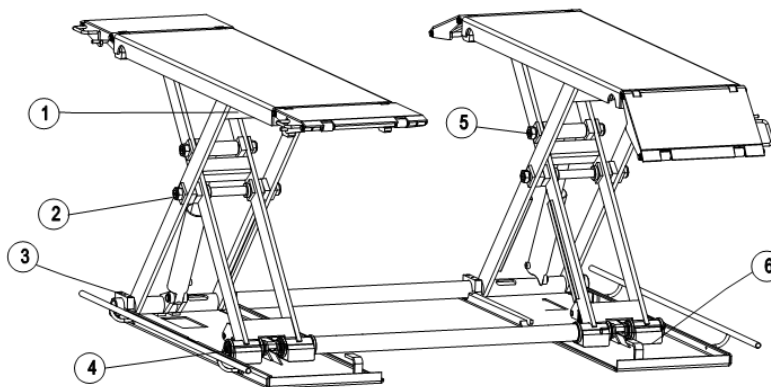

6.1. Daily checking items before operation

The user must perform daily check. Daily check of safety lock system is very important – the discovery of device failure before action could save your time and prevent you from great loss, injury or casualty.

- Before operation, judge whether the safety lock is engaged by sound.
- Check whether oil hose well connected and whether it leaks or not.
- Check the electrical system.
- Check whether plug bolts firmly screwed.
- Check if safety teeth and safety block matched well or not.

6.2. Weekly checking items

- Check the flexibility of moving parts.
- Check the working conditions of safety parts.
- Check the amount of oil left in the oil tank. Oil is enough if the platforms can be raised to highest position. Otherwise, oil is insufficient.
- Check whether plug bolts firmly screwed.

6.3. Monthly checking items

- Check whether plug bolts firmly screwed.
- Check the tightness of the hydraulic system and screw firm the joints if it leaks.

6.4. Yearly checking items

- Empty the oil tank and check the quality of hydraulic oil.
- Wash and clean the oil filter.

If users strictly follow the above maintenance requirements, the lift will keep in a good working condition and meanwhile accidents could be avoided to a large extent.

7. ANNEX

Annex 1, Packing List of the whole lift

S/N	Name	Drawing #/Spec.	Qty
1	SCT-7530 Mechanical Assembly	000	1
2	Mobile kit		Optional
2.1	Wheel	A25-B1	2
2.2	Prop trough	A25-B2	1
2.3	All directional wheel	A25-B3	1
3	Feet protector	A1-B7	2
4	Hydraulic system	A24	1
5	Inside hex screw	M8*12	4

Annex2, Overall diagram

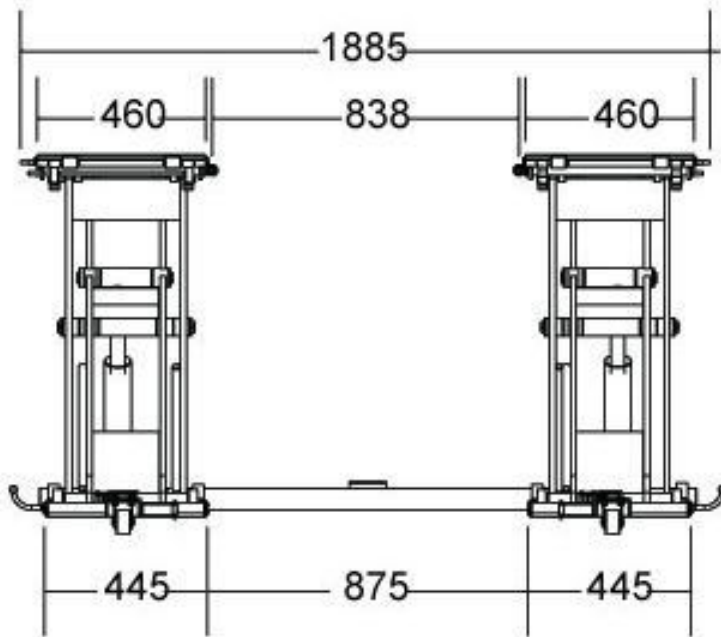
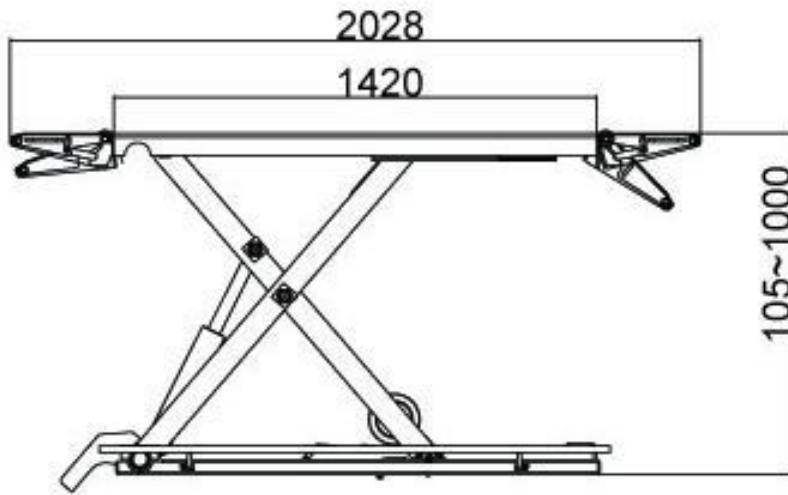

Annex3, Diagram for pneumatic system. (Only applicable to the version with pneumatic release mechanical lock)

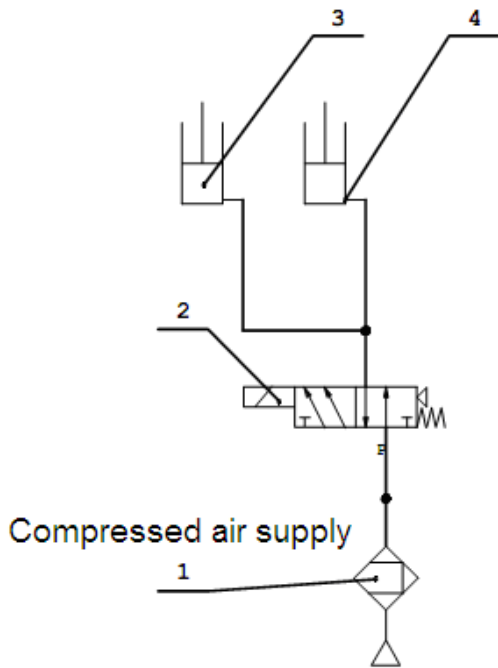

1. Air filter
2. Pneumatic solenoid valve
3. Pneumatic cylinder for the main platform
4. Pneumatic cylinder for the assistant platform

Annex 4, Hydraulic working system

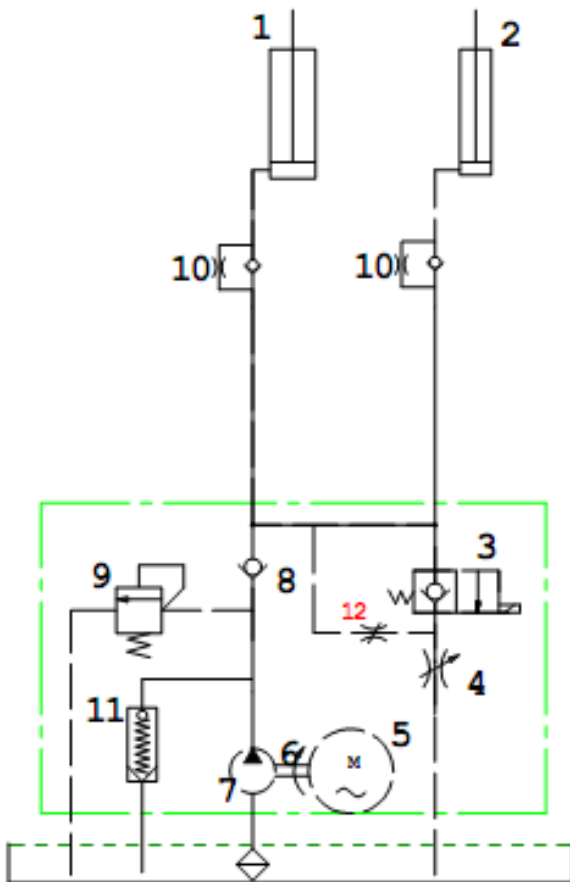

1. Driving cylinder
2. Assistant cylinder
3. Electrical release valve
4. Lowering throttle valve
5. Motor
6. Coupling
7. Gear pump
8. One-way valve
9. Over-flowing valve
10. Anti-surge valve
11. Cushion valve
12. Emergent unloading valve

Annex5, Wiring diagram

Wiring diagram for electrical system with common transformer
Single phase

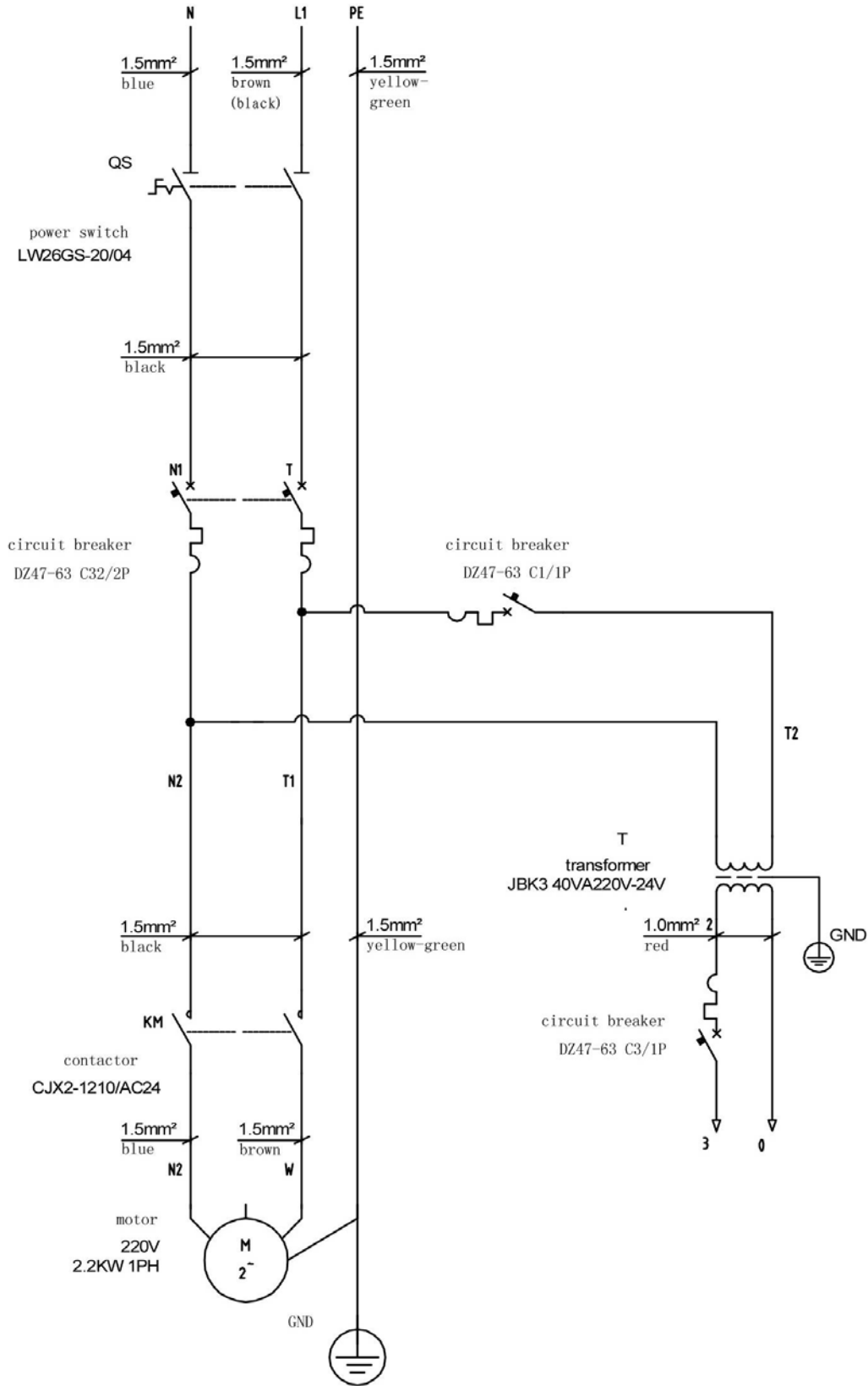

Three phase

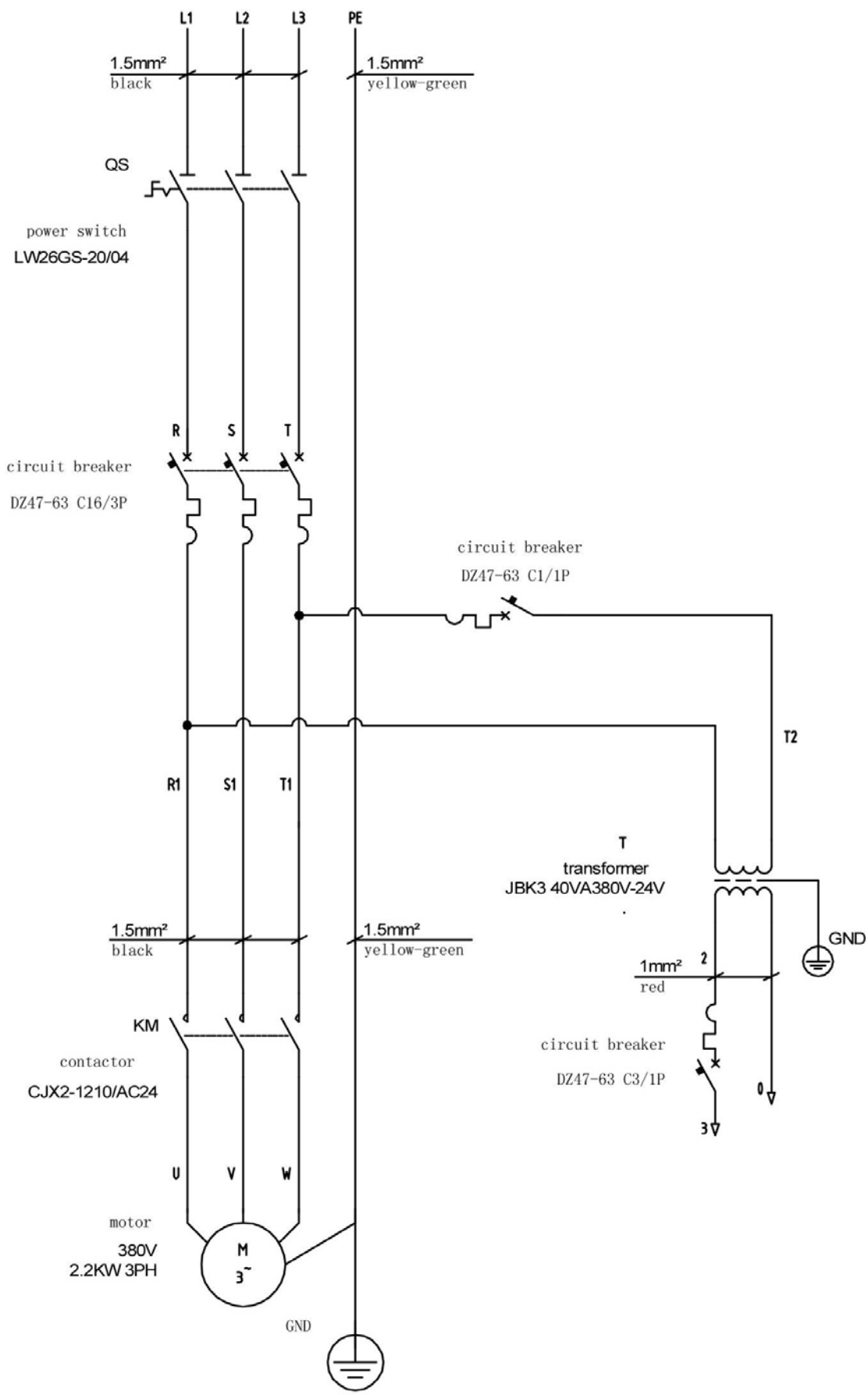

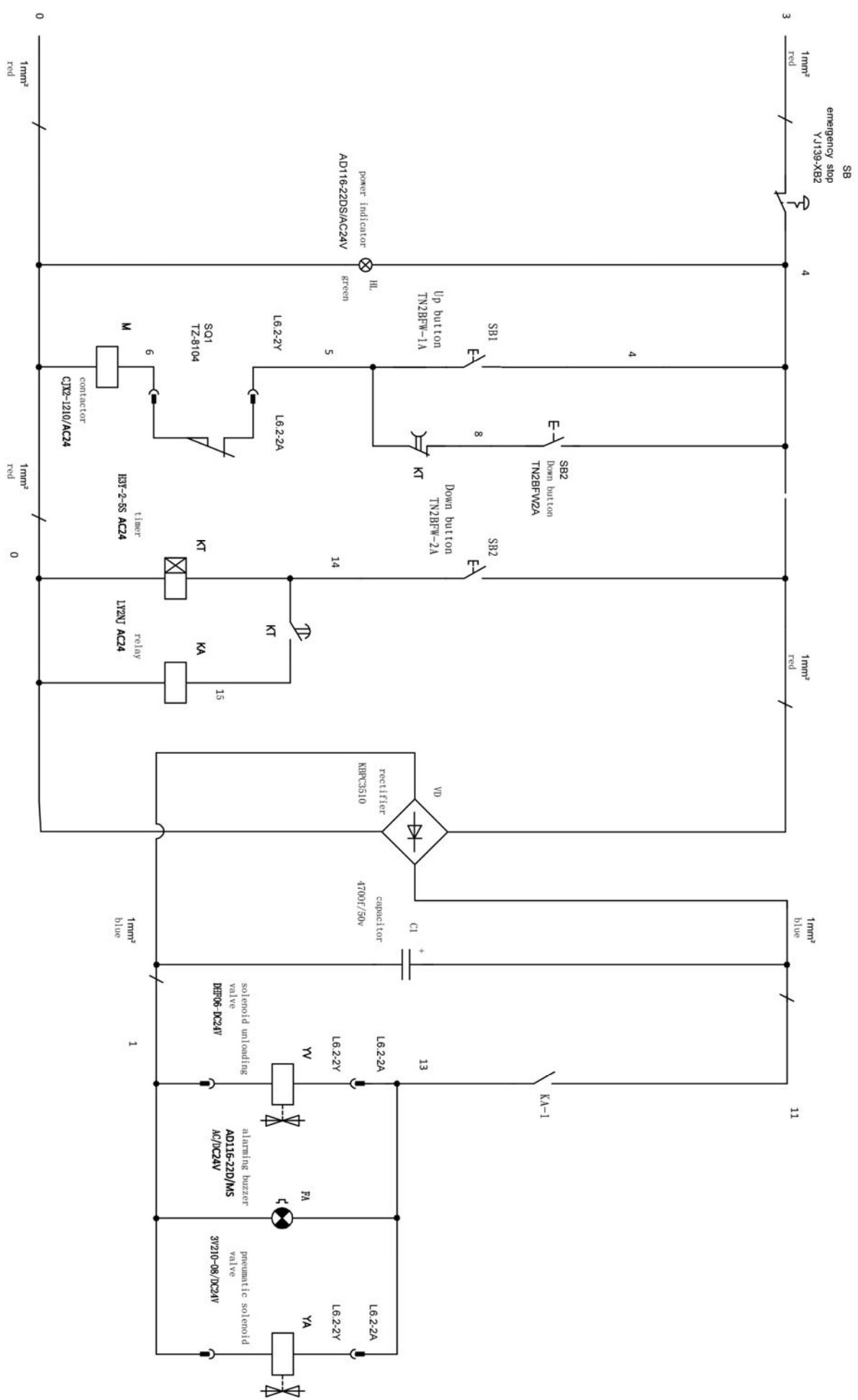

Inside layout of control box
Single phase

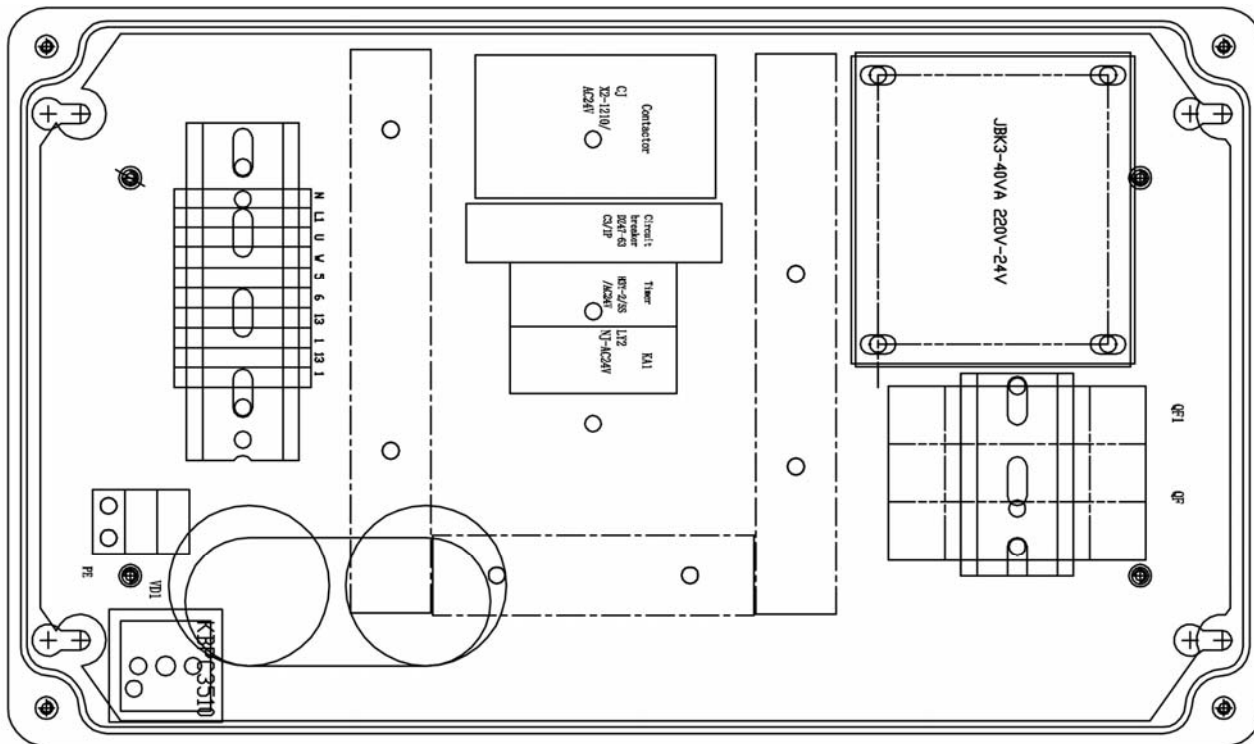

Three phase

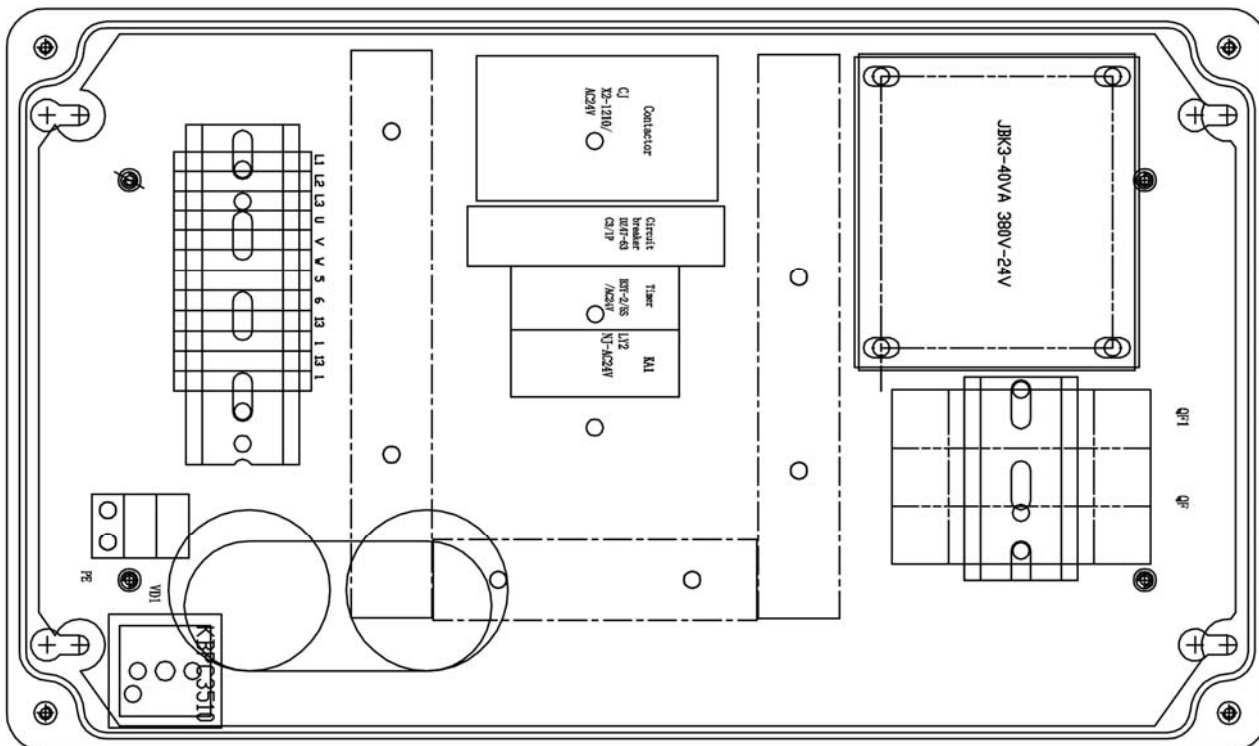

Annex 6, Separate diagrams for the lift

For the pump:

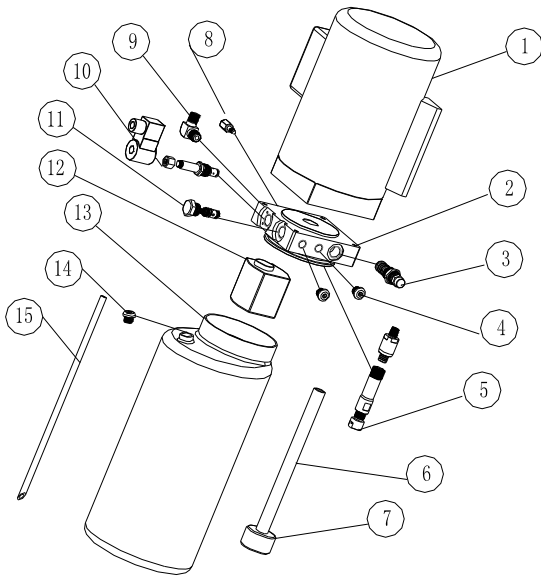

S/N	DESCRIPTION	QTY
1	MOTOR	1
2	HYDRAULIC BLOCK	1
3	OVERFLOW VALVE	1
4	FITTING	2
5	CUSHION VALVE	1
6	ABSORBING OIL PIPE	1
7	OIL FILTER	1
8	THROTTLE VALVE	1
9	OIL HOSE TIE-IN	1
10	ELECTRICAL UNLOADING VALVE	1
11	SINGLE-WAY VALVE	1
12	GEAR PUMP	1
13	OIL TANK	1
14	OIL TANK COVER	1
15	OIL BACK PIPE	1

For the lift

Version with pneumatic safety lock

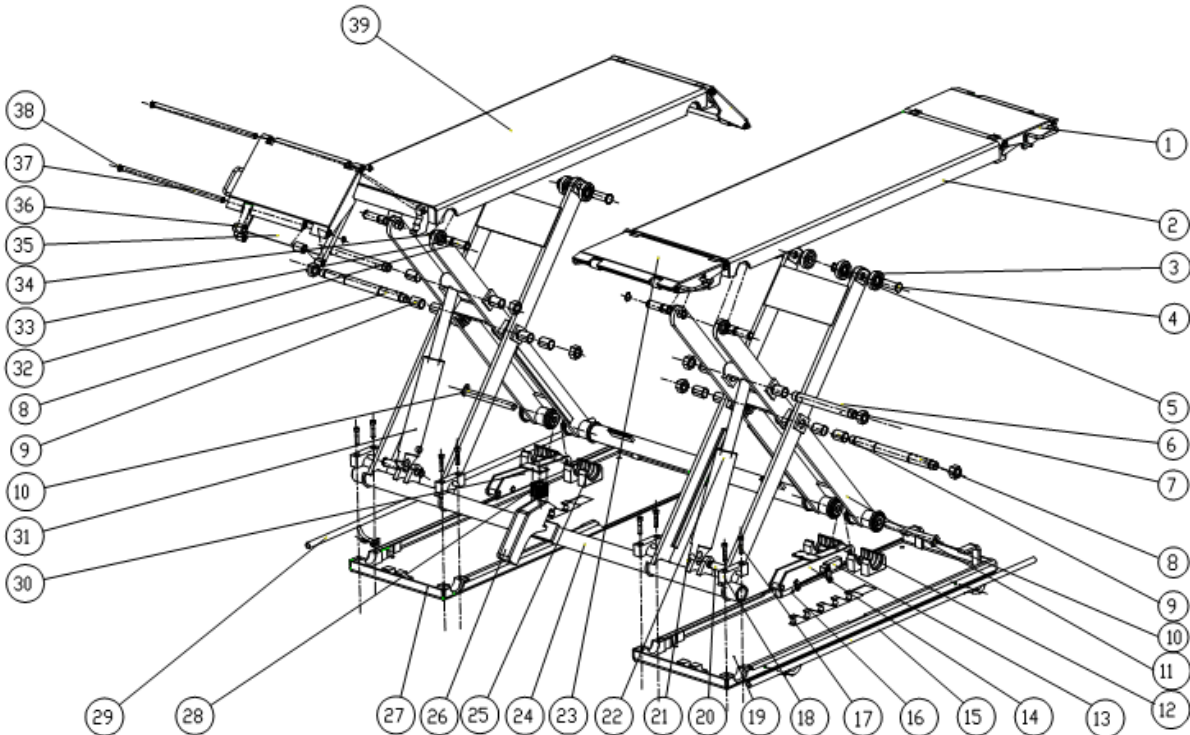

Version without pneumatic safety lock

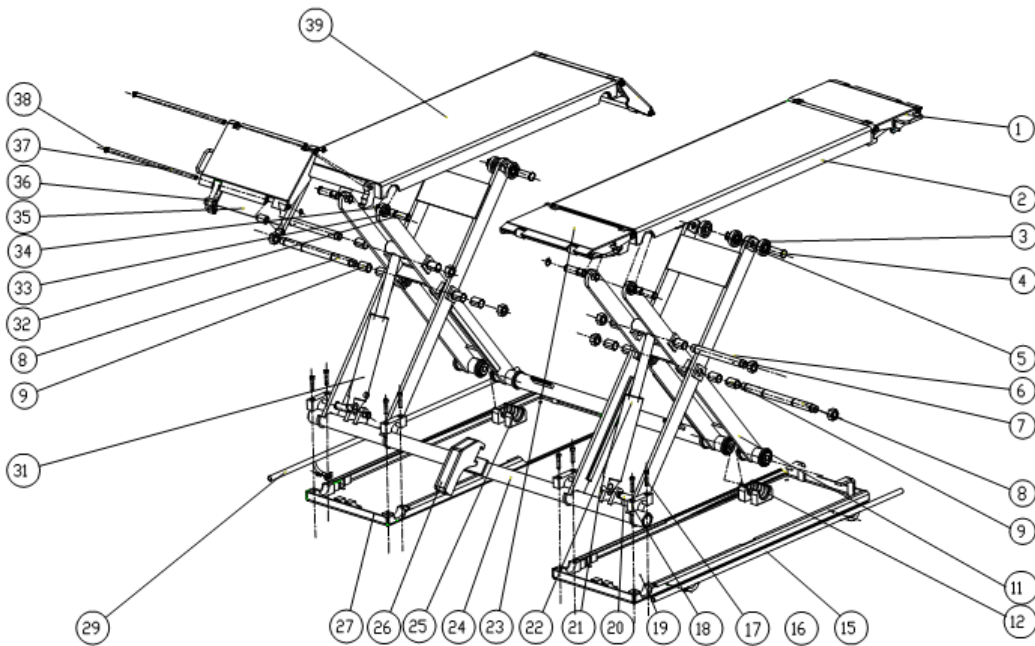



S/N	Material No.	Name	Drawing #/Spec.	Qty	Note
1		Ramp assembly A	A22	2	
2		Platform assembly B	A20	1	
3		Small idler wheel	A8	4	
4		Shaft	A9	2	
5		Circlip for the shaft	D25	4	
6		Swing shaft	A17	2	
7		Self-lock screw	A18/ M27	8	
8		X shape shaft	A7	2	
9		Oilless bearing	3045	12	
10		Security shaft	A5-B14	2	
11		Driving assembly	A5	2	
12		Nylon Slider	A5-B6	2	
13		Limit switch	ME-8108	2	
14		Safety lock holder	A5-B15	1	
15		Feet protector	A1-B7	2	
16		Limit switch	ME-8104	1	
17		Inside hex screw	M10x50	8	
18		U-shape block	A4	8	
19		Right base assembly	A2	1	
20		Fasten shaft for oil tank	A16	2	
21		Elastic flange	D25	4	
22		Oil cylinder(right)	A15-B2	1	
23		Guiding plate B	A23	2	
24		Drive assembly	A3	1	



S/N	Material No.	Name	Drawing #/Spec.	Qty	Note
25		Nylon slider	A5-B6	2	
26		Prop-trough	A25-B2	1	
27		Left base assembly	A1	1	
28		Air tank	CQ2B32x20	2	
29		Feet protector	A1-B7	1	
30		Safety lock holder	A5-B15	1	
31		Oil cylinder (left)	A15-B1	1	
32		Shaft to fasten platforms	A21	4	
33		Oilless bearing	2525	4	
34		Circlip for the shaft	D25	8	
35		Prop assembly	A22-B6	4	
36		Small idler wheel	A22-B5	8	
37		Shaft of guiding plate	A22-B4	8	
38		Elastic flange	D15	16	
39		Platform assembly A	A19	1	

Annex 7.Spare parts list

Spare parts list---electrical system

S/N	Material No.	Name	Spec.	Qty	Unit	Pic.
1		Power switch	LW26GS-20/04	1	Pcs	
2		Button	Y090-11BN	1	Pcs	
3		Power indicator	AD17-22G-AC24	1	Pcs	
4		Transformer	JBK3-40VA380V-24 V JBK3-40VA220V-24 V	1	Pcs	

S/N	Material No.	Name	Spec.	Qty	Unit	Pic.
5		AC contactor	CJX2-1210/AC24	1	Pcs	
6		Circuit breaker	DZ47-63 C16/3P DZ47-63 C32/2P	1	Pcs	
7		Circuit breaker	DZ47-63 C1/1P	1	Pcs	
8		Circuit breaker	DZ47-63 C3 /1P	1	Pcs	
9		Limit switch	YBLX-ME8104	1	Pcs	
10		Limit switch	8108 (TZ8108)	2	Pcs	
11		Emergency stop	Y090-11ZS/red	1	Pcs	
12		Bridge rectifier	KBPC5A-35A	1	Pcs	
13		Capacitor	4700UF/50A	1	Pcs	

S/N	Material No.	Name	Spec.	Qty	Unit	Pic.
14		Relay	LY2NJ/DC24	1	Pcs	
15		Relay holder	PTF-08A-E	1	Pcs	
18		Control box	190*380*135	1	Pcs	

Spare parts list---machine part

S/N	Name	Drawing #/Spec.	Qty	Note
1	Self-lock screw	A18/ M27	8	
2	Security shaft	A5-B14	2	
3	Nylon Slider	A5-B6	2	
4	Limit switch	ME-8108	2	
5	Safety lock holder	A5-B15	1	
6	Feet protector	A1-B7	2	
7	Limit switch	ME-8104	1	
8	U-shape block	A4	8	
9	Oil cylinder (right)	A15-B2	1	
10	Nylon slider	A5-B6	2	

Model	A (mm)	B (mm)	C (mm)	D (T)	E (T)	F (T)	G (T)

11	Air cylinder	CQ2B32x20	2	
12	Safety lock holder	A5-B15	1	
13	Oil cylinder (left)	A15-B1	1	

Annex8 , Size and weight requirements on vehicles

SCT-7530	1600	2000	110	1.8	1.2	1.2	1.8
----------	------	------	-----	-----	-----	-----	-----



Note: Offers may differ as per different requirements on the version.